

# Recommended Installation of Patch Antennas

## Spectrum Control, Inc.

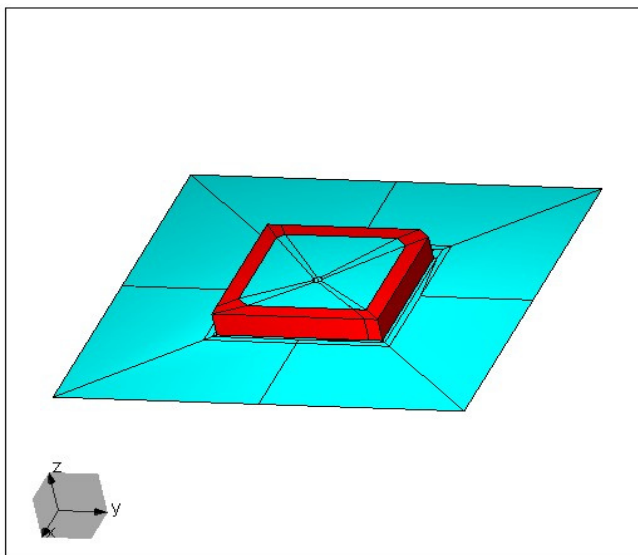
10 January 2011

The performance of a patch antenna is greatly affected by how it is installed in its application. This document will cover several aspects to keep in mind when designing an antenna system.

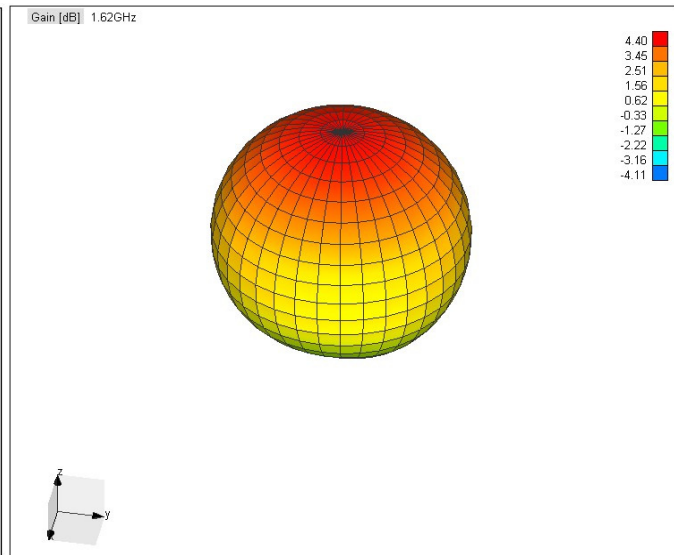
### *Ground Plane Considerations*

All Spectrum Control patch antennas are designed for use with a ground plane. The size and geometry of this ground plane will affect the radiation pattern. The proper size of the ground plane varies with each antenna. Please refer to the individual sales drawings for the recommended size of the ground plane.

Figure 1 below shows a patch antenna correctly mounted on a ground plane. Notice the antenna is centered on a square surface. A symmetrical ground plane is critical in achieving the radiation pattern shown in Figure 2. The ground plane area should be clear of all other components in the system that will affect the pattern. Metallic objects within the ground plane area should be avoided; this includes objects along the edges of the patch as well as on top of the antenna.

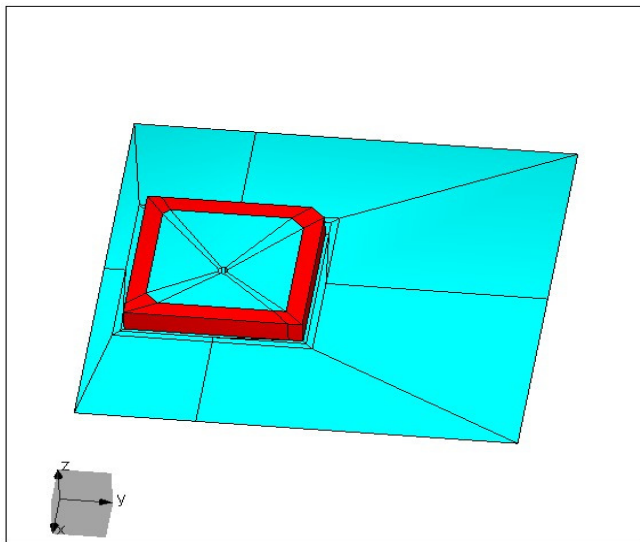


**Figure 1.** A patch antenna correctly mounted on a ground plane.

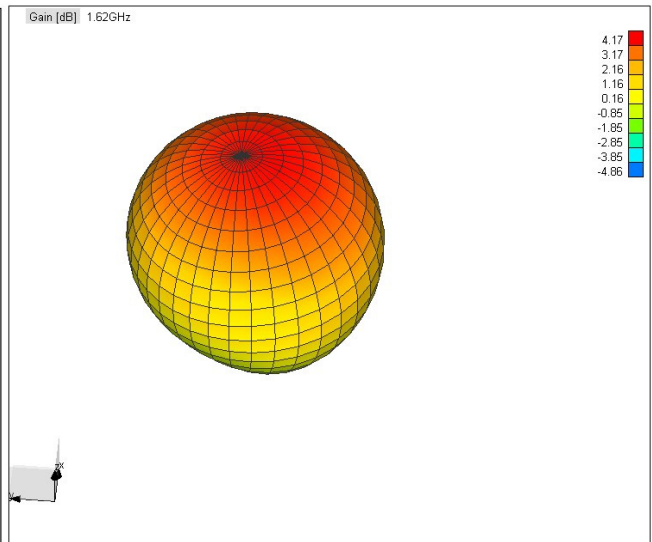


**Figure 2.** Radiation pattern of a patch antenna when installed correctly.

Figure 3 below shows a patch antenna placed off-center on a ground plane. Fig. 4 shows the “tilt” in the radiation pattern towards the larger surface of the ground plane. A symmetrical pattern is very important when attempting to close the link with a satellite.



**Figure 3.** A patch antenna not centered on a ground plane.



**Figure 4.** Locating the patch off-center shifts the pattern towards the larger side of the ground plane.

As the size of the ground plane increases, the boresight gain increases and the gain at lower elevation angles will decrease. The ground plane is directing more of the gain straight overhead. This can also cause the operating frequency to increase. As the size of the ground plane decreases, the boresight gain decreases and the gain at lower elevation angles will increase. The antenna is acting more isotropic as the ground plane size decreases. This can also cause the operating frequency to decrease.

### *Radomes*

Many applications require a radome to protect the internal components of a system. Enclosures surrounding the antenna will have an effect on performance. The two main characteristics of a plastic that affect RF performance are dielectric constant and loss tangent. The dielectric constant of a radome material will determine the shift in frequency. The loss tangent determines how much of the RF signal will be dissipated in the material. Radome material should be selected so that dielectric constant and loss tangent are as low as possible. Metal will block the RF signal and can not be used to cover the antenna.

#### **Recommended Radome Materials:**

- ABS Plastic
- Teflon
- Polypropylene
- Polystyrene
- Polycarbonate

Another consideration is the spacing between the patch antenna and the radome. An air gap in between the materials will help to minimize the effect of the radome.

## *Cable Losses and Impedance Matching*

Coaxial cables have loss associated with them that decreases the gain of the overall antenna system. The cable length should be kept as short as possible to reduce the amount of loss. Also, each type of cable has a different loss and the correct cable should be chosen based on the application.

### **Recommended RF Cables:**

- **RG-316**
- **LMR 100**
- **RG-223**
- **RG-178**

Another design consideration is the impedance of the transmission lines on printed circuit boards. All of our patches are 50 $\Omega$  antennas and the feed lines should also be designed for 50 $\Omega$  to eliminate mismatch losses.

Please contact the Antenna Engineering department with any questions about implementing our patch antennas.